

- ▶ EASIER PROGRAMMING
- ▶ 4 QUADRANTS OPERATIVITY
- ▶ LCD GRAPHIC DISPLAY
- ▶ LIGHTED KEYBOARD
- ▶ MEASURE CIRCUIT SEPARATED FROM SUPPLY
- ▶ INSTANT SYSTEM STATUS VIEW (VISIO system)
- ▶ DOUBLE Cosφ PROGRAMMABLE
- ▶ SELF-EXTINGUISHED MATERIAL UL94 V0



EU Directives - CE Marking:

- > 2014/30/UE - EMC
- > 2014/35/UE - LVD

TECHNICAL DATA

	UNIT	EPFCA05
Supply voltage AC	V~	230 - 400 (range 220 - 440)
Operating Limits (Ue)	%	-15 / +10
Nominal Frequency	Hz	50 - 60 (range 47 - 63)
Power Consumption (max. AC)	VA	5.8
Immunity Time For Microbreakings	ms	< 30
Display Type	-	64x128 Dot Matrix LCD COG
Rated Current (CT)	A	5
Voltage Reading Limits (N/Lx)	V~	10 - 460
Current Reading Limits (CT)	A	0.020 - 5.5
Measuring Values	-	True RMS
Power Factor Correction	-	0.85 Ind - 0.95 Cap (operates in all Four-Quadrants)
FFT - Harmonic Spectrum	THD %	64 st
Number of Output	Relay	5
Serial Interface	-	RS-485 (not insulated)
Communication Protocol	-	Owner - Modbus RTU or TCP/IP
Working temperature	°C	-10 / +50
Storage temperature	°C	-30 / +70
Electrical Insulation	kV	4
Oversoltage Category	-	II
Protection degree	IP	41 Front Cover - 20 Terminal Block Connections
Pollution degree	-	2
Relative Humidity w/o cond.	RH%	90
Altitude up to	m	2000
Weight	g	520
Dimensions	mm	96 x 96 x 86

DIMENSIONS (mm)

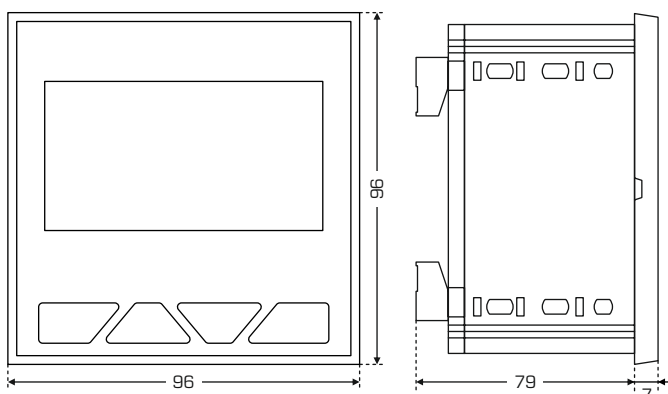

WIRING DIAGRAM

